

CRE



107/2 Albert Street Randwick NSW

1  1  2 

With its oversized layout, streamlined designer interiors and superb village setting, this 67sqm apartment evokes the essence of stylish contemporary living across the street from the Royal Randwick Shopping Centre. Set on the first floor of the architect- designed Natalie Apartments, this one-bedroom apartment captures ocean glimpses from a deep balcony and is footsteps to first-class shopping and entertainment and minutes to Coogee Beach, UNSW and major hospitals.

- Streamlined interiors, stylish finishes
- 67sqm of living plus double parking
- Deep balcony with ocean glimpses
- Open layout with entertainer's kitchen
- Double bedroom with built-in wardrobe and modern bathroom

View : <https://www.coogee realestate.com.au/sale/nsw/eastern-suburbs/randwick/residential/apartment/5903140>



James Giltinan
02 9665 3341



CAR STACKING
ON SECURE CARPARK
[2 CARS]
5.60 X 2.75

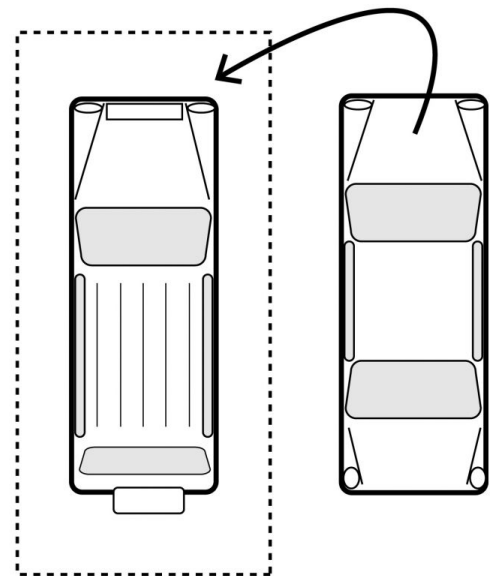

107 / 2 Albert Street
RANDWICK
"NATALIE APARTMENTS"